

訂正者 Designed	訂正事項 Content	訂正日 Date	訂正記号 Rev. No.	訂正者 Designed	変番 Ver.	訂正事項 Content	訂正日 Date	訂正記号 Rev. No.	訂正者 Designed	変番 Ver.	訂正事項 Content	訂正日 Date	訂正記号 Rev. No.
				N.Marukai	V2	定格電圧、全容量タップ電圧記号追加 (R、F)	17.04.06	3	N.Marukai	V2			
				N.Marukai	V2	2次電流表記変更(909→100)	17.04.06	4	N.Marukai	V2			
		17.04.06	1			規格JEM 1333廃止に伴い規格変更	17.04.06						
		17.04.06	2			規格変更に伴い耐圧試験値変更(2.5kV→4kV)	17.04.06						

回路図  
Circuit Diagram

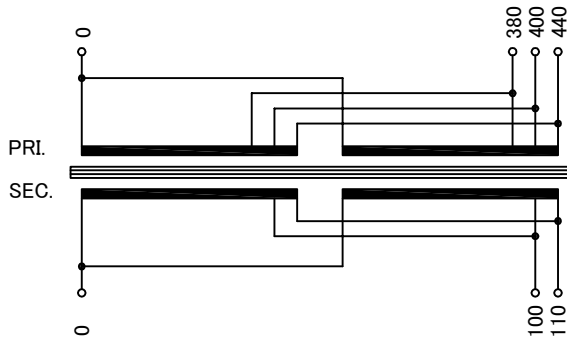

仕様 Specification	
定格 Rating	Cont.
容量 Capacity	10kVA
相数 Phase	1φ
周波数 Frequency	50/60Hz
一次電圧 Primary Volt.	F380/R400/F440V
二次電圧 Secondary Volt.	R100/F110V
二次電流 Secondary Curr.	100A
耐熱クラス Class	H
質量 Mass	61kg
絶縁抵抗 Insulation Resistance	
P-E P-S S-E	
100MΩ Min. at DC1000V	
絶縁耐圧 Dielectric Withstand Volt.	
P-E P-S	AC 60Hz 4.0kV / 1min.
S-E	AC 60Hz 2.0kV / 1min.
準拠規格 Standard	
JEC-2200-2014 JEM 1310-2001	

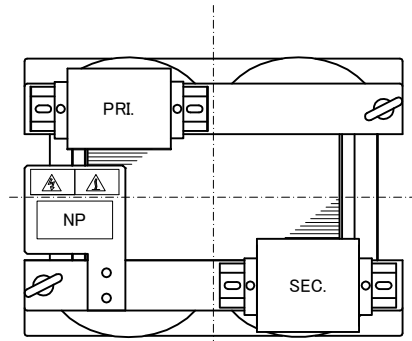

端子台 Terminals

PRI. PT-90 4P M6 締付トルク 3.7N・m  
SEC. PT-150 3P M8 締付トルク 9.0N・m

端子台配列 Terminals Arrangement

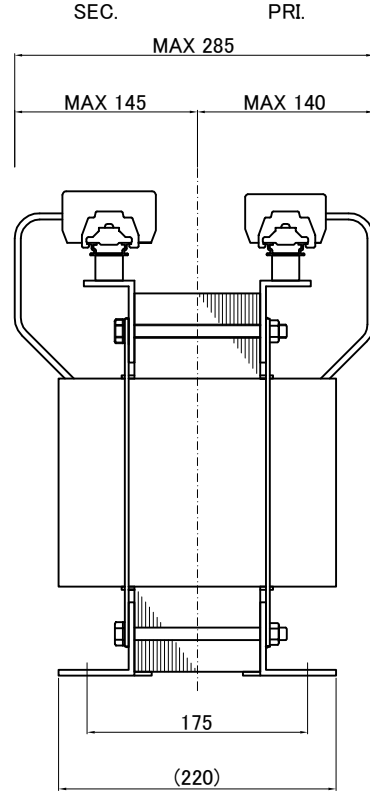
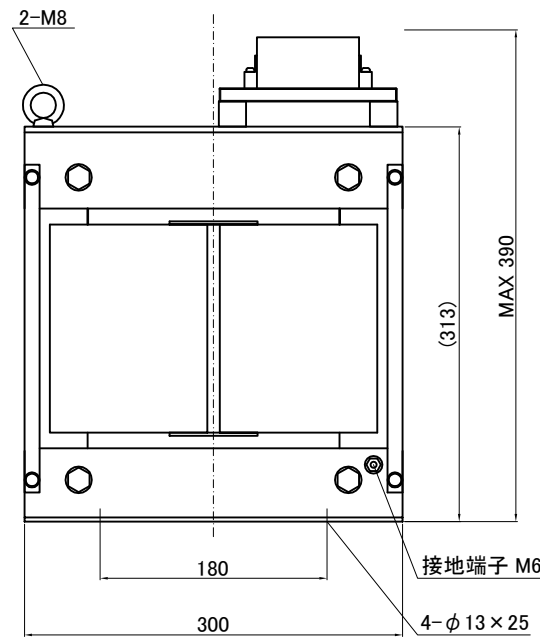
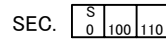
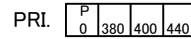

質量は標準仕様の値を記入しており、実測値と異なる場合があります。

IMAI ELECTRIC CO., LTD. JAPAN	設計 Date	14.02.28	品名 Description	单相乾式複巻変圧器 Dry-type Insulation Transformer		材料 Material	表面処理 Finish	摘要 Remarks
	作図 Designed	M.Fujitaka	承認 Approved	N.Marukai	単位 Unit	mm	尺度 Scale	
	今井電機株式会社				型名 Model	TBL-010-31		
				図番 Dwg.No.	STBL010Q31-V2			