

訂正者 Designed		訂正事項 Content		訂正日 Date		訂正記号 Rev. No.		訂正者 Designed		訂正事項 Content		訂正日 Date		訂正記号 Rev. No.		訂正者 Designed		訂正事項 Content		訂正日 Date		訂正記号 Rev. No.	
改番 Ver.																							

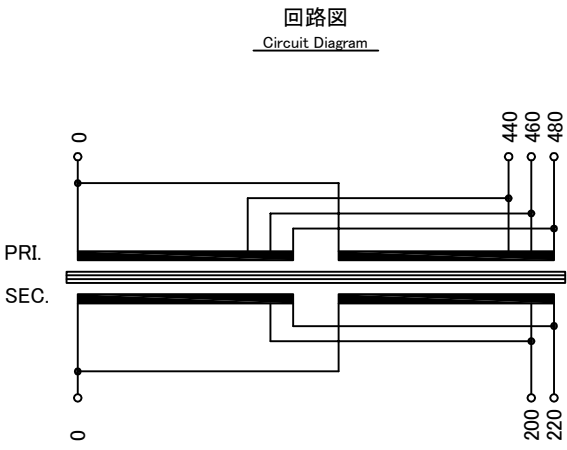

仕様 Specification	
定格 Rating	Cont.
容量 Capacity	15kVA
相数 Phase	1φ
周波数 Frequency	50/60Hz
一次電圧 Primary Volt.	F440/R460/F480
二次電圧 Secondary Volt.	R200/F220V
二次電流 Secondary Curr.	75A
耐熱クラス Class	H
質量 Mass	85kg
絶縁抵抗 Insulation Resistance	
P-E P-S S-E	
100MΩ Min. at DC1000V	
絶縁耐圧 Dielectric Withstand Volt.	
P-E P-S	AC 60Hz 4.0kV / 1min.
S-E	AC 60Hz 2.0kV / 1min.
準拠規格 Standard	
JEC-2200-2014 JEM 1310-2001	

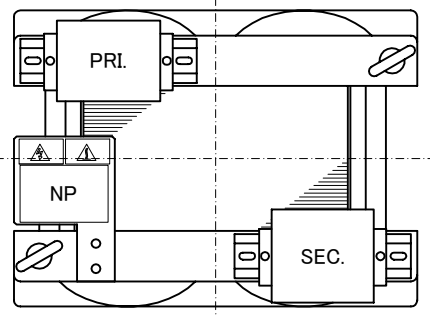

端子台 Terminals
 PRI. PT-90 4P M6 締付トルク 3.7N・m
 SEC. PT-150 3P M8 締付トルク 9.0N・m

端子台配列 Terminals Arrangement

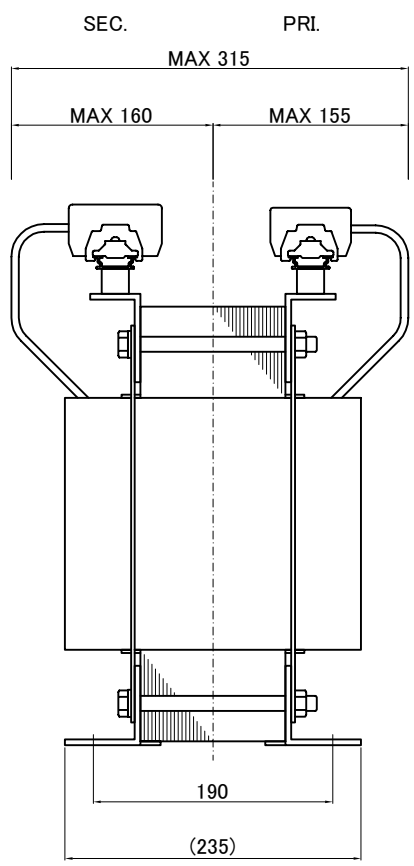
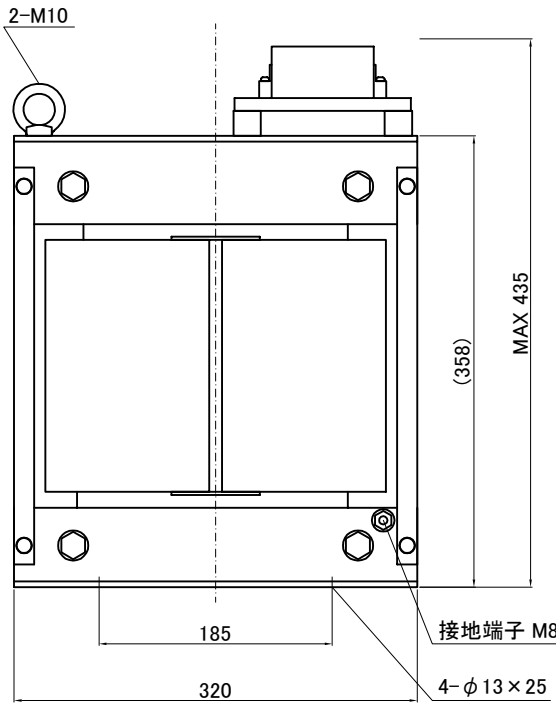
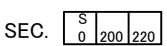
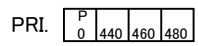

IMAI ELECTRIC CO., LTD. JAPAN	設計 Date	16.06.14	品名 Description	单相乾式複巻変圧器 Dry-type Insulation Transformer		材料 Material	表面処理 Finish	摘要 Remarks
	作図 Designed	M.Fujitaka	承認 Approved	N.Marukai	単位 Unit	尺度 Scale	型名 Model	TBL-015-92
	今井電機株式会社					図番 Dwg.No.	STBL015Q92-V2	