

回路図
Circuit Diagram

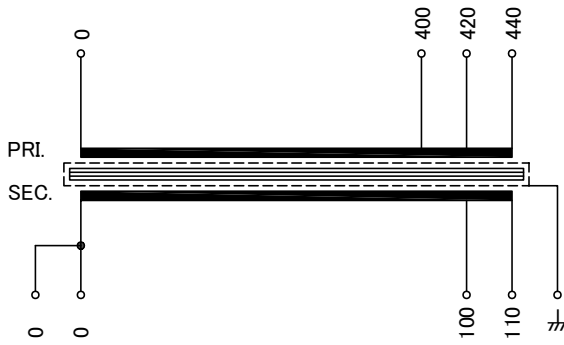

仕様 Specification	
定格 Rating	Cont.
容量 Capacity	750VA
相数 Phase	1φ
周波数 Frequency	50/60Hz
一次電圧 Primary Volt.	F400/R420/F440V
二次電圧 Secondary Volt.	R100/F110V
二次電流 Secondary Curr.	7.5A
絶縁種別 Class	B
質量 Mass	10.8kg
絶縁抵抗 Insulation Resistance	
P-E P-S S-E	
100MΩ Min. at DC1000V	
絶縁耐圧 Dielectric Withstand Volt.	
P-E P-S	AC 60Hz 2.5kV / 1min.
S-E	AC 60Hz 2.0kV / 1min.
準拠規格 Standard	
JIS C6436-1995/JIS C5310-1997	
極性 Polarity	
減極性 Subtractive polarity	
♣: シールド端子	

端子台 Terminals
PTV 2.5 12P
接続電線サイズ AWG26-12
単線0.14-4mm²

端子台配列 Terminals Arrangement

S	S	100	110	P	400	420	440	♣
0	0			0				

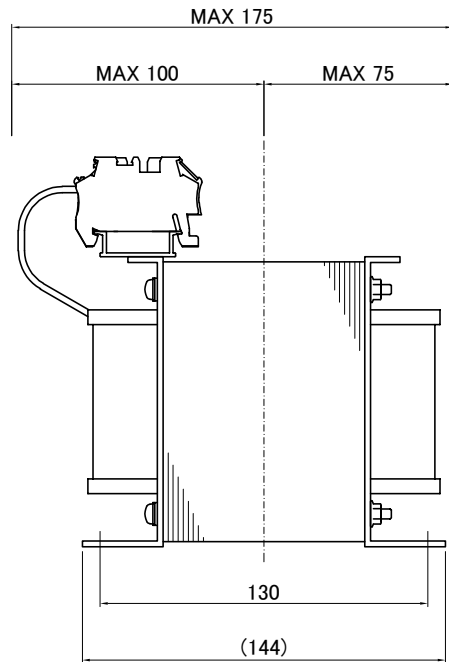
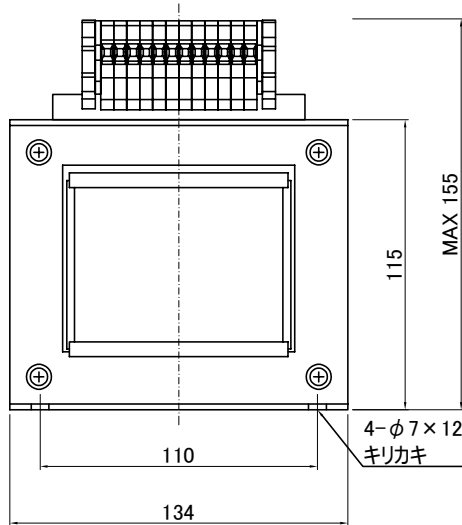
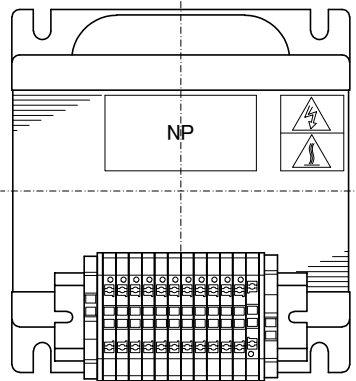

質量は標準仕様の値を記入しており、実測値と異なる場合があります。

訂正者 Revised By	訂正日 Revised Date	訂正事項 Revised Content
改訂 Ver.		
訂正者 Revised By	訂正日 Revised Date	訂正事項 Revised Content
改訂 Ver.		
訂正者 Revised By	訂正日 Revised Date	訂正事項 Revised Content
改訂 Ver.		
訂正者 Revised By	訂正日 Revised Date	訂正事項 Revised Content
改訂 Ver.		

IMAI ELECTRIC
今井電機株式会社

設計 DESIGNED
DATE 20.10.06
DRAWN
N.Marukai
APPROVED
M.Fujitaka

品名 DESCRIPTION
単相乾式複巻変圧器
Dry type Isolating Transformer
尺度 SCALE
単位 UNIT
mm
表面処理 FINISH

型名
MODEL
図番
DWG.NO.

摘要 REMARKS

SDN-750S-51

SSDN075051S0

改訂
Ver.