

回路図
Circuit Diagram

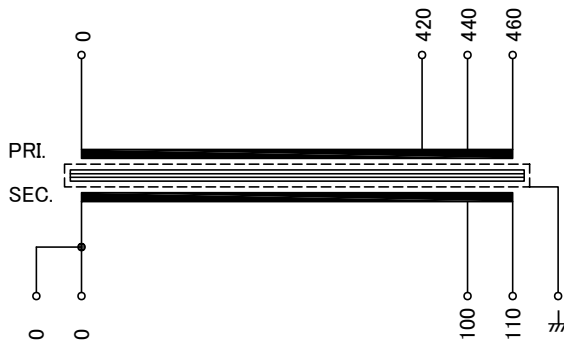

仕様
Specification

定 格 Rating	Cont.	
容 量 Capacity	300VA	
相 数 Phase	1φ	周波数 Frequency
一次電圧 Primary Volt.	F420/R440/F460V	
二次電圧 Secondary Volt.	R100/F110V	
二次電流 Secondary Curr.	3A	
絶縁種別 Class	B	質 量 Mass
絶縁抵抗 Insulation Resistance		
P-E P-S S-E		100MΩ Min. at DC1000V
絶縁耐圧 Dielectric Withstand Volt.		
P-E P-S	AC 60Hz	2.5kV / 1min.
S-E	AC 60Hz	2.0kV / 1min.
準拠規格 Standard	JIS C6436-1995/JIS C5310-1997	
極 性 Polarity	減極性 Subtractive polarity	
カ: シールド端子		

端子台 Terminals

PTV 2.5 12P

接続電線サイズ AWG26-12

単線0.14-4mm²

端子台配列 Terminals Arrangement

S	S		P					
0	0	100	110	0	420	440	460	カ

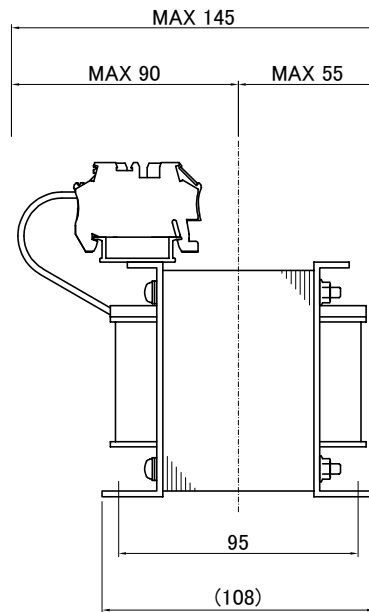
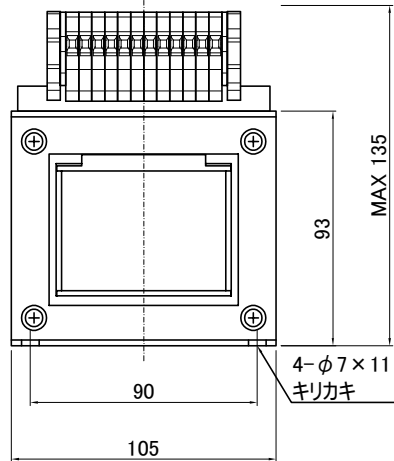
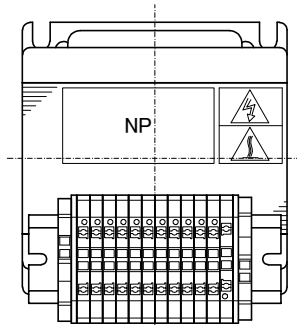

質量は標準仕様の値を記入しており、実測値と異なる場合があります。

訂正者 Revised By	訂正日 Revised Date	訂正事項 Revised Content
改訂 Ver.		
訂正者 Revised By	訂正日 Revised Date	訂正事項 Revised Content
改訂 Ver.		
訂正者 Revised By	訂正日 Revised Date	訂正事項 Revised Content
改訂 Ver.		
訂正者 Revised By	訂正日 Revised Date	訂正事項 Revised Content
改訂 Ver.		

IMAI ELECTRIC
今井電機株式会社

設計 DESIGNED
DATE 20.10.06
DRAWN
N.Marukai
APPROVED
M.Fujitaka

品名 DESCRIPTION
単相乾式複巻変圧器
Dry type Isolating Transformer
尺度 SCALE
単位 UNIT
mm
表面処理 FINISH

型 名
MODEL
図 番
DWG.NO.

摘要 REMARKS

SDN-300S-71

SSDN030071S0

改訂
Ver.