

回路図  
Circuit Diagram

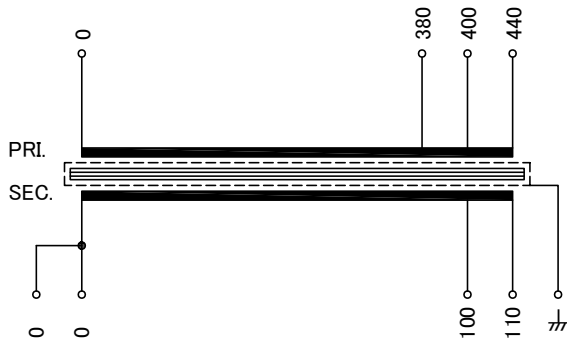

仕様 Specification	Cont.	
定格 Rating	容量 Capacity 1.5kVA	
相数 Phase 1φ	周波数 Frequency 50/60Hz	
一次電圧 Primary Volt. F380/R400/F440V		
二次電圧 Secondary Volt. R100/F110V		
二次電流 Secondary Curr. 15A		
絶縁種別 Class F	質量 Mass 16kg	
絶縁抵抗 Insulation Resistance		
P-E P-S S-E		
100MΩ Min. at DC1000V		
絶縁耐圧 Dielectric Withstand Volt.		
P-E P-S AC 60Hz 2.5kV / 1min.		
S-E AC 60Hz 2.0kV / 1min.		
準拠規格 Standard JIS C6436-1995/JIS C5310-1997		
極性 Polarity 減極性 Subtractive polarity		
♣: シールド端子		

端子台 Terminals  
PTV 4 12P  
接続電線サイズ AWG24-10  
単線0.2-6mm<sup>2</sup>

端子台配列 Terminals Arrangement

S	S		P				
0	0	100	110	0	380	400	440 ♣

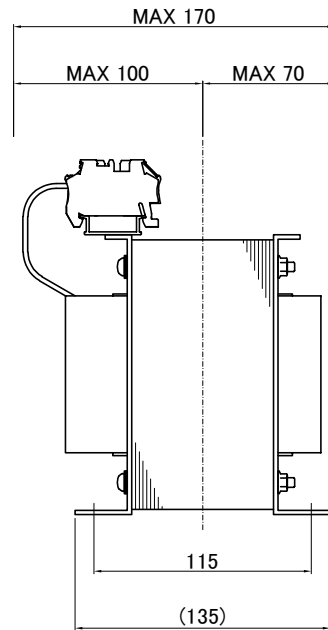
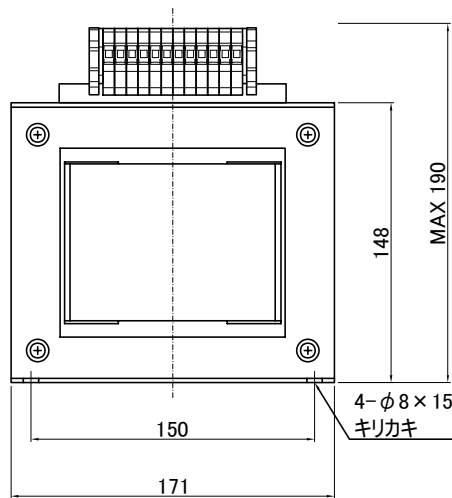
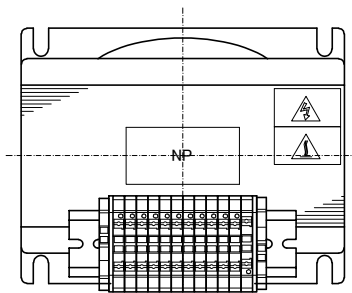

質量は標準仕様の値を記入しており、実測値と異なる場合もあります。

訂正者 Drawn	訂正日 Date	訂正事項 Comment
改訂 Ver.	改訂日 Date	改訂事項 Comment
訂正者 Drawn	訂正日 Date	訂正事項 Comment
改訂 Ver.	改訂日 Date	改訂事項 Comment
訂正者 Drawn	訂正日 Date	訂正事項 Comment
改訂 Ver.	改訂日 Date	改訂事項 Comment

IMAI ELECTRIC 今井電機株式会社	設計 DESIGNED DATE 20.10.06	品名 DESCRIPTION 単相乾式複巻変圧器 Dry type Isolating Transformer	摘要 REMARKS
	DRAWN N.Marukai	尺度 SCALE 単位 UNIT mm	型名 MODEL SDN-1500S-31
	APPROVED M.Fujitaka	表面処理 FINISH	図番 DWG.NO. SSDN150031S0
			改訂 Ver.