

回路図
Circuit Diagram

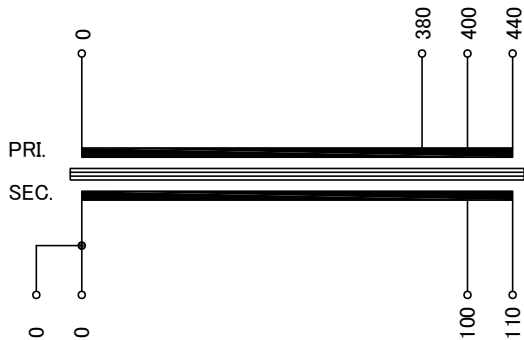

仕様 Specification	Cont.	
定格 Rating	容量 Capacity	
	1kVA	
相数 Phase	1φ	周波数 Frequency
		50/60Hz
一次電圧 Primary Volt.	F380/R400/F440V	
二次電圧 Secondary Volt.	R100/F110V	
二次電流 Secondary Curr.	10A	
絶縁種別 Class	B	質量 Mass
		8kg
絶縁抵抗 Insulation Resistance	100MΩ Min. at DC1000V	
P-E P-S S-E		
絶縁耐圧 Dielectric Withstand Volt.		
P-E P-S	AC 60Hz 2.5kV / 1min.	
S-E	AC 60Hz 2.0kV / 1min.	
準拠規格 Standard	JIS C6436-1995/JIS C5310-1997	
極性 Polarity	減極性 Subtractive polarity	

訂正者 Revised By	訂正日 Revised Date	訂正事項 Revised Content
改訂 Ver.		
訂正者 Revised By	訂正日 Revised Date	訂正事項 Revised Content
改訂 Ver.		
訂正者 Revised By	訂正日 Revised Date	訂正事項 Revised Content
改訂 Ver.		
訂正者 Revised By	訂正日 Revised Date	訂正事項 Revised Content
改訂 Ver.		

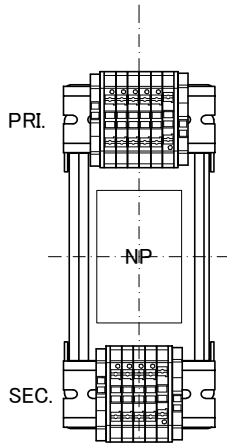

端子台 Terminals
PRI. PTV 4 6P
SEC. PTV 4 5P
接続電線サイズ AWG24-10
単線0.2-6mm²

端子台配列 Terminals Arrangement

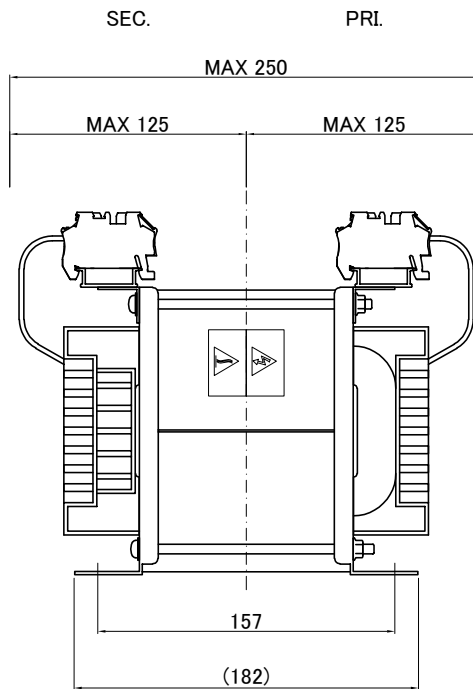
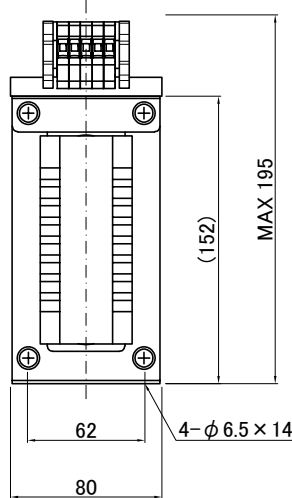
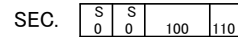
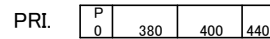

質量は標準仕様の値を記入しており、実測値と異なる場合があります。

IMAI ELECTRIC
今井電機株式会社

設計 DESIGNED
DATE 20.10.06
DRAWN
N.Marukai
APPROVED
M.Fujitaka

品名 DESCRIPTION
単相乾式複巻変圧器
Dry type Isolating Transformer
尺度 SCALE
単位 UNIT
mm
表面処理 FINISH

型名
MODEL
SDB-1000A-31
図番
DWG.NO.

摘要 REMARKS

SDB-1000A-31

SDBA100031X0

改訂
Ver.