

回路図
Circuit Diagram

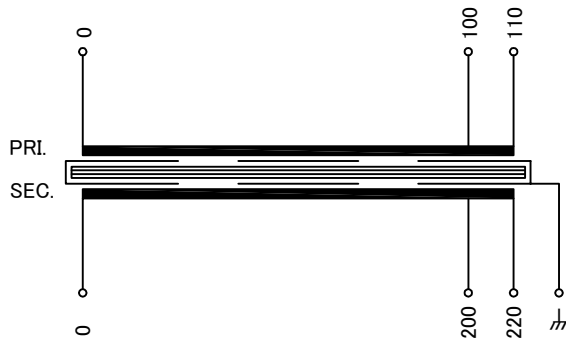

仕様
Specification

定 格 Rating	Cont.	
容 量 Capacity	2kVA	
相 数 Phase	1φ	周 波 数 Frequency
一次電圧 Primary Volt.	R100/F110V	
二次電圧 Secondary Volt.	R200/F220V	
二次電流 Secondary Curr.	10A	
絶縁種別 Class	F	質 量 Mass
絶縁抵抗 Insulation Resistance		
P-E P-S S-E		
100MΩ Min. at DC1000V		
絶縁耐圧 Dielectric Withstand Volt.		
P-E AC 60Hz 2.0kV / 1min.		
P-S S-E AC 60Hz 2.0kV / 1min.		
準拠規格 Standard		
JIS C6436-1995/JIS C5310-1997		
極 性 Polarity		
減極性 Subtractive polarity		
♣ : 静電シールド端子		

端子台 Terminals

CTKC-35S-8P M5 締付トルク 2.0-3.0N・m

端子台配列 Terminals Arrangement

S	P					
0	200	220	0	100	110	♣

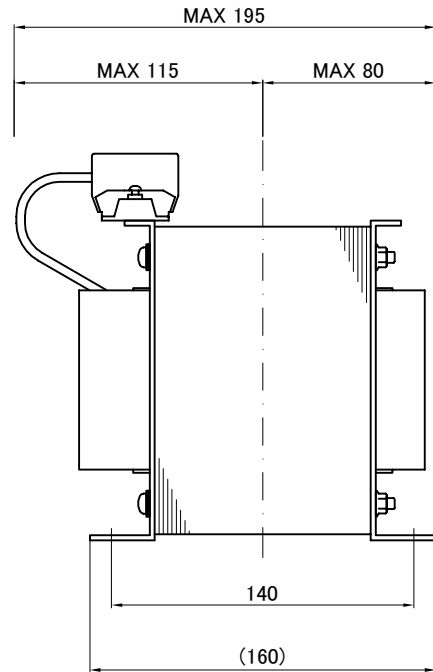
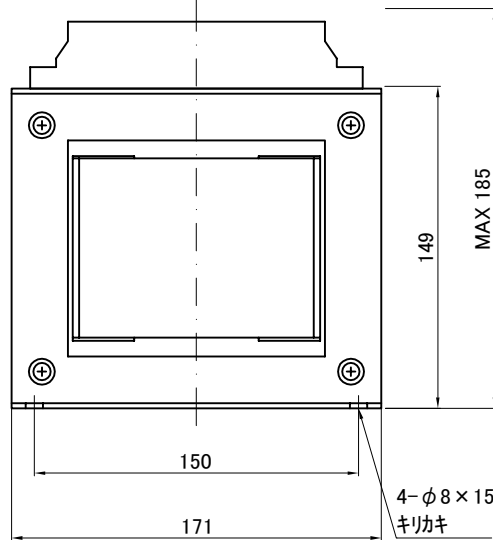
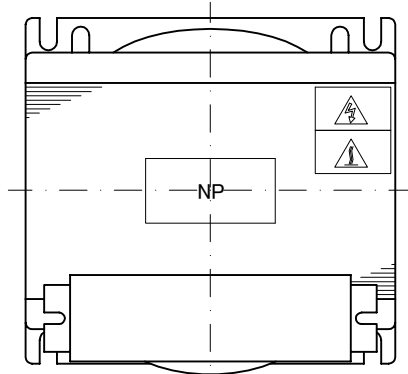

質量は標準仕様の値を記入しており、実測値と異なる場合もあります。

訂正者 Checked by	訂正日 Checked date	訂正事項 Correction
改訂 Rev.		
訂正者 Checked by	訂正日 Checked date	訂正事項 Correction
改訂 Rev.		
訂正者 Checked by	訂正日 Checked date	訂正事項 Correction
改訂 Rev.		
訂正者 Checked by	訂正日 Checked date	訂正事項 Correction
改訂 Rev.		

IMAI ELECTRIC
今井電機株式会社

設計 DESIGNED
DATE 20.11.13
DRAWN
N.Takebayashi
APPROVED
M.Fujitaka

品名 DESCRIPTION
単相乾式複巻変圧器
Dry type Isolating Transformer
尺度 SCALE 単位 UNIT
mm
表面処理 FINISH
型 名 MODEL
NBS-2000S-12
図 番 DWG.NO.

摘要 REMARKS

NBS-2000S-12

SNBS200012S0

改訂
Ver.