

回路図
Circuit Diagram

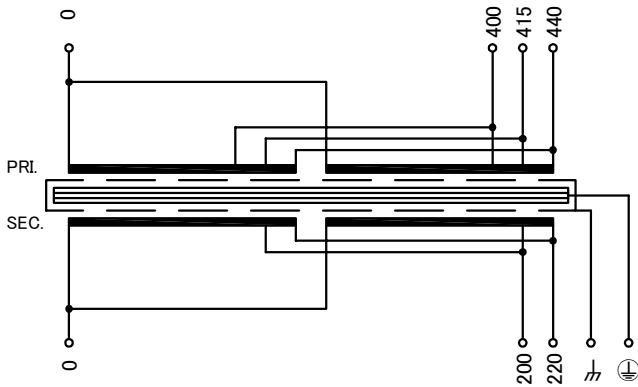

端子台配列 Terminal arrangement

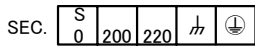
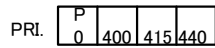

端子台 Terminal

(締付トルク Tightening Torque)
 PRI. PT-90 4P M6 (2.5~3.7N・m)
 SEC. PT-90 3P M6 (2.5~3.7N・m)
 ⌚ ⊕ PT-90 2P M6 (2.5~3.7N・m)

仕様 Specification	連続 Cont.
定格 Rating	容量 Capacity
10kVA	10kVA
相数 Phase	周波数 Frequency
1~	50/60Hz
1次電圧 Primary Volt.	400/415/440V
2次電圧 Secondary Volt.	200/220V
2次電流 Secondary Curr.	50/45.5A
絶縁抵抗 Insulation Resistance	P-E P-S S-E 100MΩ Min. at DC500V
絶縁耐圧 Dielectric Withstand Volt.	P-E AC 60Hz 4.0kV / 1min. P-S AC 60Hz 5.0kV / 1min. S-E AC 60Hz 2.5kV / 1min.
トランス質量 Transformer Mass	95kg
絶縁種別 Insulation Class	Class 180(H)
定格周囲温度 Ambient Temp.	40°C
適用規格 Standard	UL5085-1, UL5085-2 C22.2 EN61558-1, EN61558-2-4 IEC61558-1, IEC61558-2-4 BS EN IEC 63000
ULファイルNo. UL File No.	E219074
EN, IECマーク EN, IEC Mark	Non short circuit proof isolating transformer
推奨保護装置定格 Recommended protection device rating	Pri. Circuit Breaker 40A Sec. Circuit Breaker 50A (IEC60947-2 or IEC60934)



訂正者 Checked	訂正事項 Comment	訂正日 Date	訂正記号 Rev. No.	改訂 Ver.	訂正事項 Comment	訂正日 Date	訂正記号 Rev. No.	改訂 Ver.
				1	EN, IEC standard update, BS standard added			

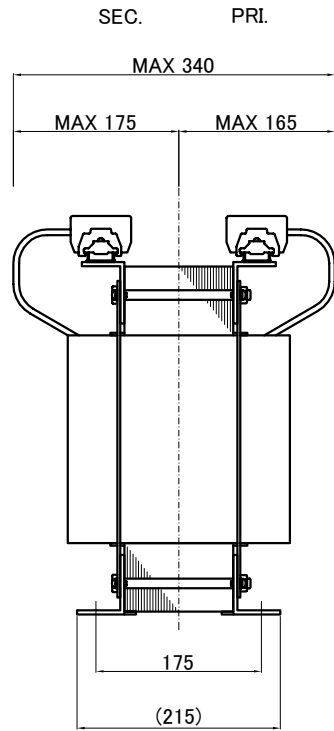
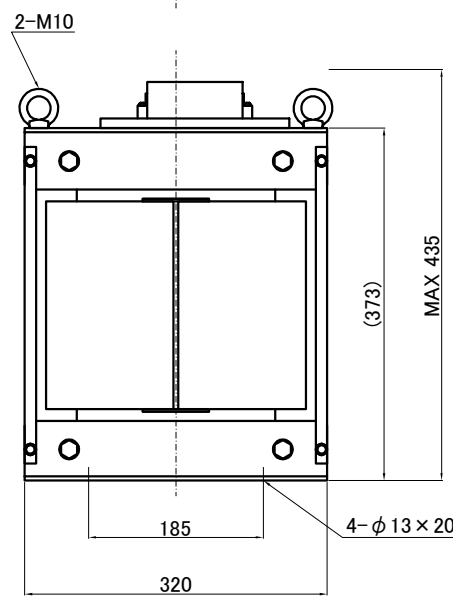
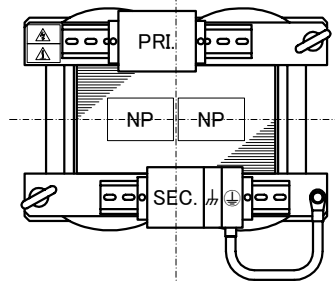

質量は標準仕様の値を記入しており、実測値と異なる場合もあります。

<p>今井電機株式会社</p>	設計 DESIGNED DATE 19.07.01	品名 DESCRIPTION Dry Type Isolating Transformer	摘要 REMARKS
	DRAWN N.Marukai	尺度 SCALE 単位 UNIT mm	型名 MODEL IUH1-B010S-873
	APPROVED M.Fujitaka	表面処理 FINISH	図番 DWG. NO. SIUH1B010873
			改訂 Ver. 1