

回路図  
Circuit Diagram

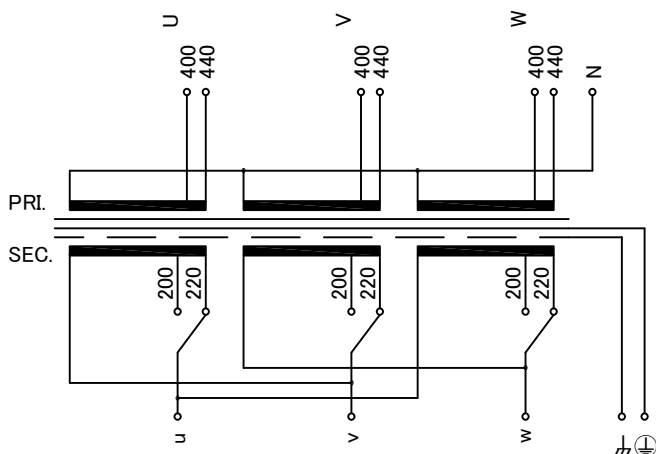

端子台配列 Terminal arrangement

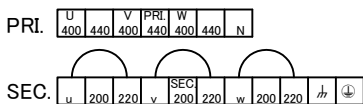

端子台 Terminal (締付トルク Tightening Torque)

- PRI. FPS(FP)-40 7P M4 (1.2~1.8N・m)
- SEC. FPS(FP)-40 9P M4 (1.2~1.8N・m)
- ⚡ FPS(FP)-40 1P M4 (1.2~1.8N・m)
- ⊕ TFE40 1P M4 (1.4~1.8N・m)

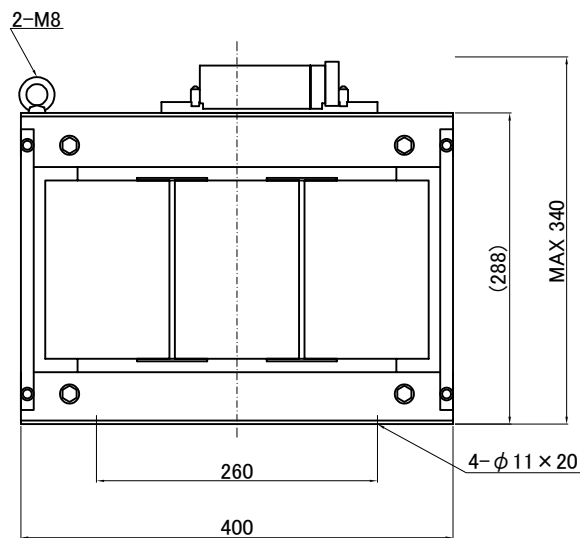
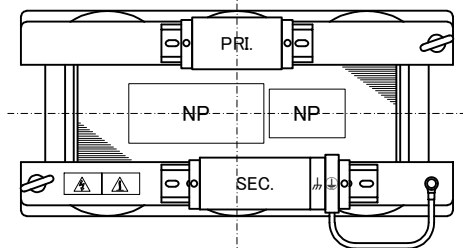

仕様  
Specification

定格 Rating	連続 Cont.	結線 Connection	$\Delta$ - $\Delta$
容量 Capacity	6.93kVA		
相数 Phase	3~	周波数 Frequency	50/60Hz
1次電圧 Primary Volt.	400/440V		
2次電圧 Secondary Volt.	200/220V		
2次電流 Secondary Curr.	20/18.2A		
絶縁抵抗 Insulation Resistance	P-E P-S S-E 100M $\Omega$ Min. at DC500V		
絶縁耐圧 Dielectric Withstand Volt.	P-E AC 60Hz 4.0kV / 1min.		
	P-S AC 60Hz 5.0kV / 1min.		
	S-E AC 60Hz 2.5kV / 1min.		
トランス質量 Transformer Mass	70kg		
絶縁種別 Insulation Class	Class 180(H)		
定格周囲温度 Ambient Temp.	40°C		
適用規格 Standard	UL1561 C22.2 No. 47-M90 EN61558-1, EN61558-2-4 IEC61558-1, IEC61558-2-4 BS EN IEC 63000		
ULファイルNo. UL File No.	E258403		
EN, IECマーク EN, IEC Mark	Non short circuit proof isolating transformer		
推奨保護装置定格 Recommended protection device rating	Pri. Circuit Breaker 20A Sec. Circuit Breaker 20A (IEC60947-2 or IEC60934)		

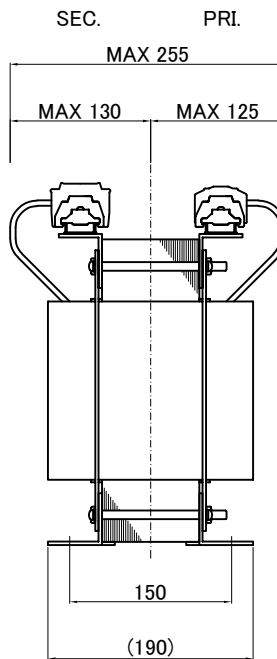

質量は標準仕様の値を記入しており、実測値と異なる場合があります。

訂正者 Drawn	訂正事項 Content	訂正日 Date	訂正記号 Rev. No.	改訂 Ver.
N.Marukai	Corrected the ambient temperature value(25°C→40°C)	19.04.16	③	4
N.Marukai	Rewrite drawing	21.07.01		5
N.Marukai	EN, IEC standard updated, BS standard added	21.07.01	④	5

IMAI ELECTRIC  
今井電機株式会社

設計 DESIGNED  
DATE 13.01.31  
DRAWN  
M.Fujitaka  
APPROVED  
S.Murakami

品名 DESCRIPTION  
Dry type Isolating Transformer  
尺度 SCALE 単位 UNIT  
mm  
表面処理 FINISH

型名  
MODEL  
図番  
DWG.NO.

摘要 REMARKS

IEH3-YDB6930S-393

SYDB6930S393

改訂  
Ver. 5