

回路図
Circuit Diagram

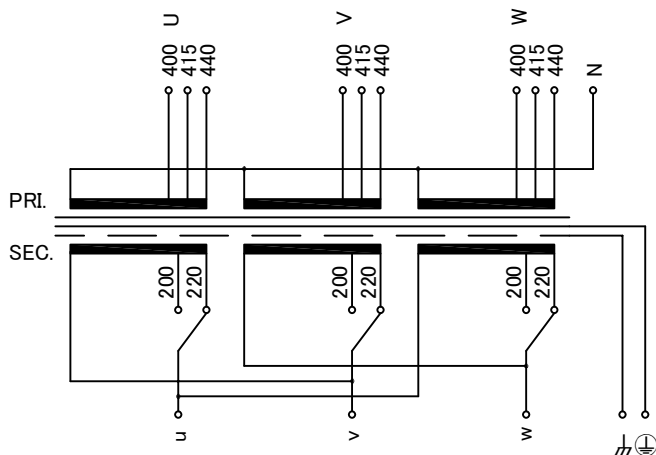

端子台配列 Terminal arrangement

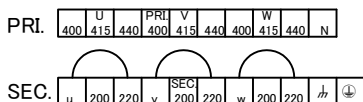

端子台 Terminal (締付トルク Tightening Torque)

PRI. PT-80 10P M5 (2.0~3.0N・m)
 SEC. PT-90 9P M6 (2.5~3.7N・m)
 接地 PT-90 2P M6 (2.5~3.7N・m)

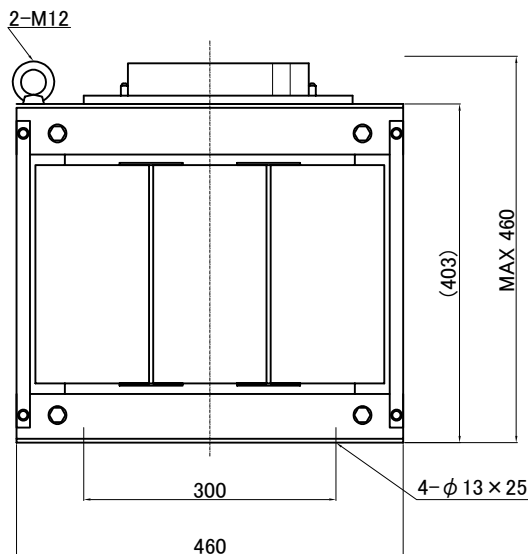
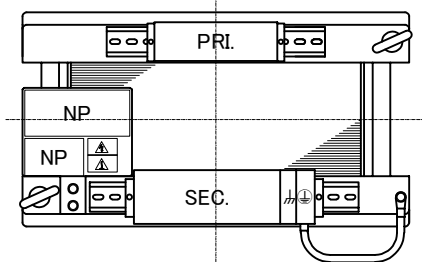

仕様
Specification

定格 Rating	連続 Cont.	結線 Connection	Δ - Δ
容量 Capacity	20.8 kVA		
相数 Phase	3~	周波数 Frequency	50/60Hz
1次電圧 Primary Volt.	400/415/440V		
2次電圧 Secondary Volt.	200/220V		
2次電流 Secondary Curr.	60/54.6A		
絶縁抵抗 Insulation Resistance	P-E P-S S-E 100MΩ Min. at DC500V		
絶縁耐圧 Dielectric Withstand Volt.	P-E AC 60Hz 4.0kV / 1min.		
	P-S AC 60Hz 5.0kV / 1min.		
	S-E AC 60Hz 2.5kV / 1min.		

トランス質量 Transformer Mass	160kg
絶縁種別 Insulation Class	Class 180(H)
定格周囲温度 Ambient Temp.	40°C
適用規格 Standard	UL1561 C22.2 No. 47-M90 EN61558-1, EN61558-2-4 IEC61558-1, IEC61558-2-4 BS EN IEC 63000

ULファイルNo. UL File No.	E258403
EN, IECマーク EN, IEC Mark	Non short circuit proof isolating transformer

推奨保護装置定格 Recommended protection device rating	Pri. Circuit Breaker 60A Sec. Circuit Breaker 60A (IEC60947-2 or IEC60934)
--	--

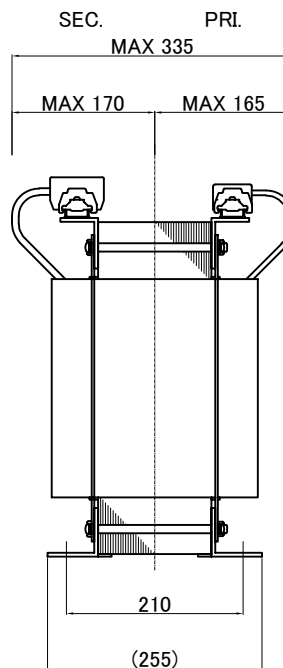

質量は標準仕様の値を記入しており、実測値と異なる場合があります。

訂正者 Drawn	訂正事項 Comment	訂正日 Date	訂正記号 Rev. No.	訂正者 Drawn	訂正事項 Comment	訂正日 Date	訂正記号 Rev. No.
N. Takebayashi	Rewrite drawing	21.07.01		N. Marukai	EN, IEC standard updated, BS standard added	21.07.01	3
N. Takebayashi				N. Marukai	Corrected the ambient temperature value (25°C → 40°C)		2
				N. Marukai			1



今井電機株式会社

設計 DESIGNED
DATE 13.01.25

DRAWN
N. Marukai

APPROVED
S. Murakami

品名 DESCRIPTION
Dry type Isolating Transformer

尺度 SCALE 単位 UNIT
mm

表面処理 FINISH
型名 MODEL
IEH3-YDB0208S-693

摘要 REMARKS

型名 MODEL
IEH3-YDB0208S-693

図番 DWG. NO.
SYDB0208S693 改訂 Ver. 4