

回路図  
Circuit Diagram

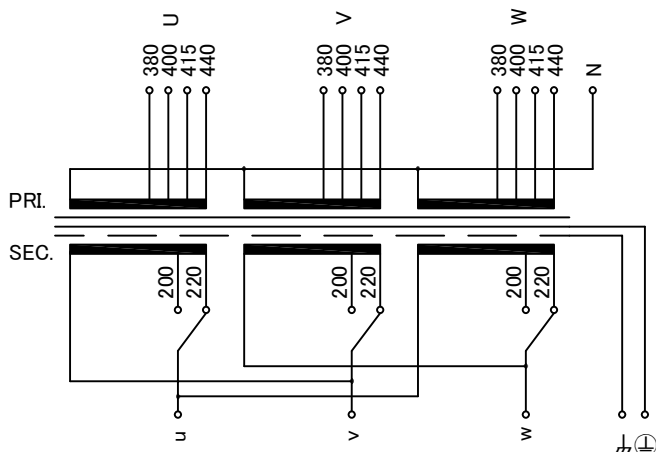

端子台配列 Terminal arrangement

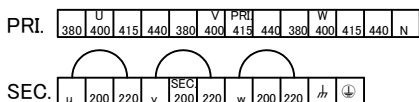

端子台 Terminal (締付トルク Tightening Torque)

PRI. PT-80 13P M5 (2.0~3.0N・m)  
 SEC. PT-80 9P M5 (2.0~3.0N・m)  
 〃 PT-80 2P M5 (2.0~3.0N・m)

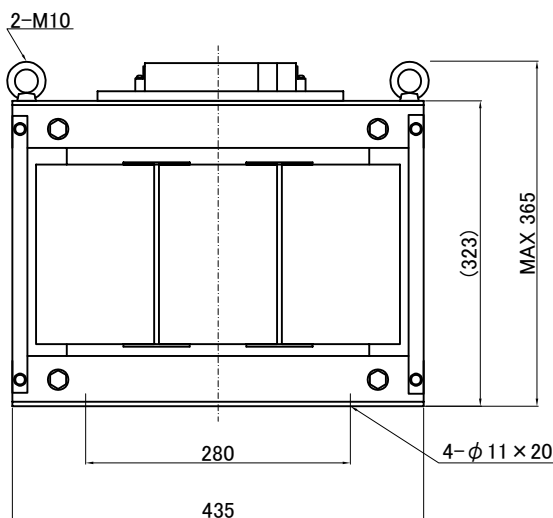
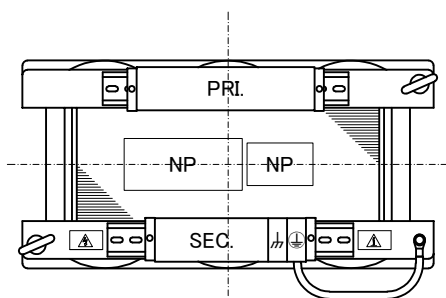

仕様  
Specification

定格 Rating	連続 Cont.	結線 Connection	$N-\Delta$
容量 Capacity	13.9 kVA		
相数 Phase	3~	周波数 Frequency	50/60Hz
1次電圧 Primary Volt.	380/400/415/440V		
2次電圧 Secondary Volt.	200/220V		
2次電流 Secondary Curr.	40/36.5A		
絶縁抵抗 Insulation Resistance	P-E P-S S-E 100MΩ Min. at DC500V		
絶縁耐圧 Dielectric Withstand Volt.	P-E AC 60Hz 4.0kV / 1min. P-S AC 60Hz 5.0kV / 1min. S-E AC 60Hz 2.5kV / 1min.		
トランス質量 Transformer Mass	110kg		
絶縁種別 Insulation Class	Class 180(H)		
定格周囲温度 Ambient Temp.	40°C		
適用規格 Standard	UL1561 C22.2 No. 47-M90 EN61558-1, EN61558-2-4 IEC61558-1, IEC61558-2-4 BS EN IEC 63000		
ULファイルNo. UL File No.	E258403		
EN, IECマーク EN, IEC Mark	Non short circuit proof isolating transformer		
推奨保護装置定格 Recommended protection device rating	Pri. Circuit Breaker 40A Sec. Circuit Breaker 40A (IEC60947-2 or IEC60934)		

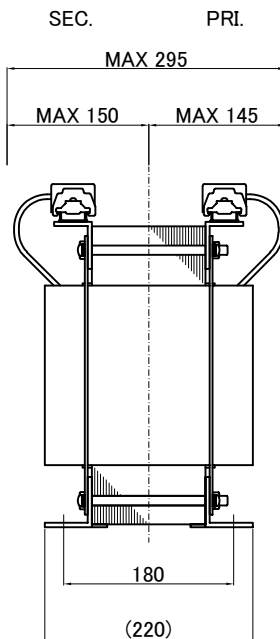

質量は標準仕様の値を記入しており、実測値と異なる場合があります。

訂正者 Drawn	訂正事項 Comment	訂正日 Date	訂正記号 Rev. No.	訂正者 Drawn	訂正事項 Comment	訂正日 Date	訂正記号 Rev. No.
N.Takebayashi	Rewrite drawing	21.07.01		N.Marukai	EN, IEC standard updated, BS standard added	21.07.01	3
N.Takebayashi				N.Marukai			
				N.Marukai	Corrected the ambient temperature value(25°C→40°C)	19.04.16	2



今井電機株式会社

設計 DESIGNED  
DATE 13.01.25

DRAWN  
N.Marukai

APPROVED  
S.Murakami

品名 DESCRIPTION  
Dry type Isolating Transformer

尺度 SCALE 単位 UNIT  
mm

表面処理 FINISH

摘要 REMARKS

型名  
MODEL  
IEH3-YDB0139S-843

図番  
DWG.NO.  
SYDB0139S843

改訂  
Ver.  
4