

訂正者 Designed		訂正事項 Content		訂正日 Date		訂正記号 Rev. No.		訂正者 Designed		訂正事項 Content		訂正日 Date		訂正記号 Rev. No.	
改番 Ver.								改番 Ver.	V2	訂正事項 Content	定格電圧、全容量タップ電圧記号追加(R、F)	17.06.06		訂正者 Designed	N.Marukai
									V2	訂正事項 Content	2次電流表記変更(11.4→12.5)	17.06.06		訂正者 Designed	N.Marukai
									V2	訂正事項 Content	規格JEM 1333廃止により変更	17.06.06		訂正者 Designed	N.Marukai
									V2	訂正事項 Content	規格変更により絶縁種別変更(B→F)	17.06.06		訂正者 Designed	N.Marukai
訂正記号 Rev. No.	1							訂正記号 Rev. No.	3					訂正記号 Rev. No.	4

回路図
Circuit Diagram

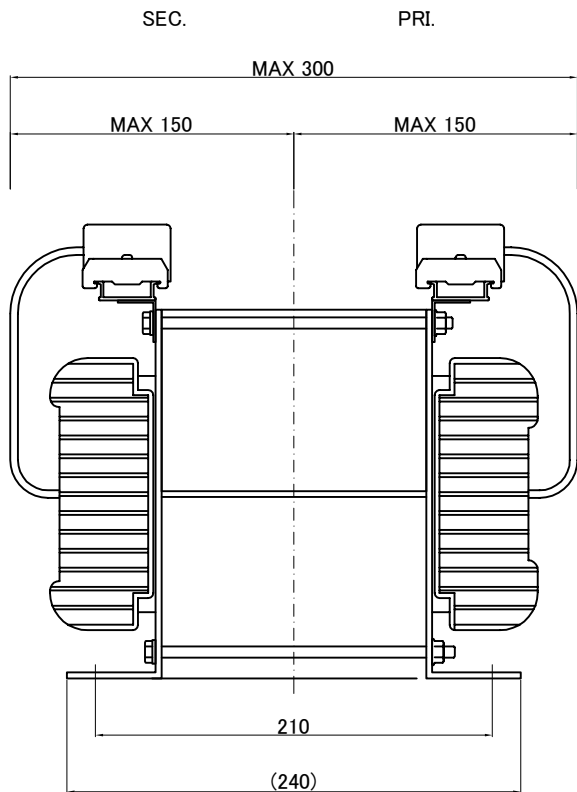
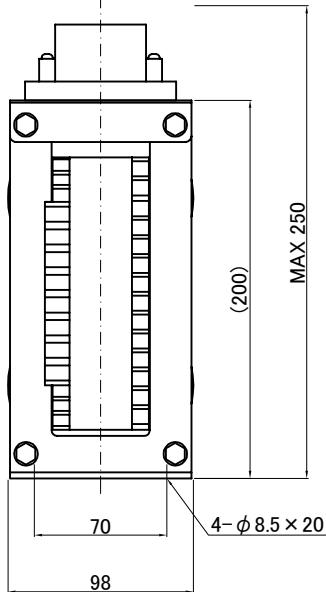
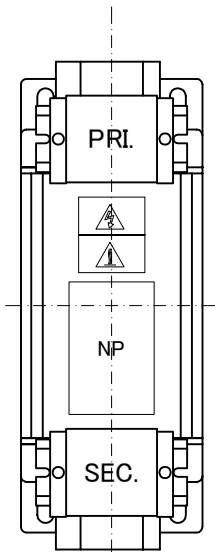
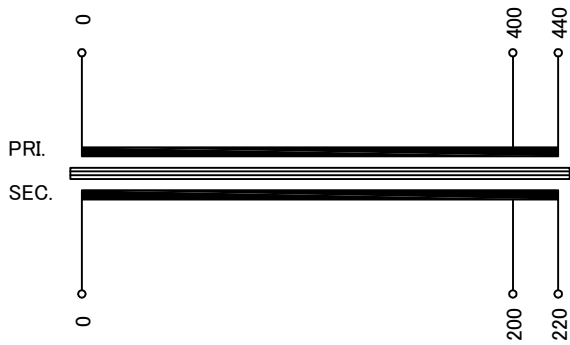

仕様
Specification

定 格 Rating	Cont.	
容 量 Capacity	2.5kVA	
相 数 Phase	1φ	周波数 Frequency
一次電圧 Primary Volt.	R400/F440V	
二次電圧 Secondary Volt.	R200/F220V	
二次電流 Secondary Curr.	12.5A	
絶縁種別 Class	F/2	質 量 Mass
絶縁抵抗 Insulation Resistance		18kg
P-E P-S S-E		
100MΩ Min. at DC1000V		
絶縁耐圧 Dielectric Withstand Volt.		
P-E P-S	AC 60Hz 2.5kV / 1min.	
S-E	AC 60Hz 2.0kV / 1min.	
準拠規格 Standard	JIS C6436-1995 JIS C5310-1997	

端子台 Terminals

PRI. PT-80 3P M5 締付トルク 3.0N・m
SEC. PT-80 3P M5 締付トルク 3.0N・m

端子台配列 Terminals Arrangement



質量は標準仕様の値を記入しており、実測値と異なる場合もあります。

IMAI ELECTRIC CO., LTD. JAPAN	設計 Date	13.06.26	品名 Description	单相乾式複巻変圧器 Dry-type Insulation Transformer		材料 Material	表面処理 Finish	摘要 Remarks
	作図 Designed	M.Fujitaka	承認 Approved	S.Murakami	単位 Unit	尺度 Scale	型 名 Model	BSW-2500A-42
					mm		図 番 Dwg.No.	S0C2500Q42-V2
今井電機株式会社								