

回路図
Circuit Diagram

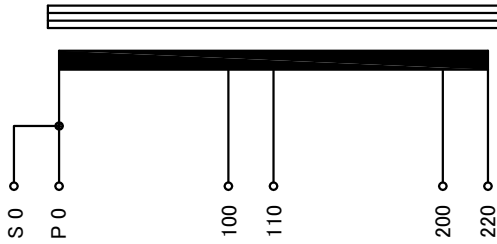

仕様 Specification	Cont.	
定格 Rating		
容量 Capacity	1.5kVA	
相数 Phase	1φ	周波数 Frequency
一次電圧 Primary Volt.	R200/F220V	
二次電圧 Secondary Volt.	R100/F110V	
二次電流 Secondary Curr.	15A	
絶縁種別 Class	B	質量 Mass
絶縁抵抗 Insulation Resistance	P-E S-E	
	100MΩ Min. at DC1000V	
絶縁耐圧 Dielectric Withstand Volt.		
P-E	AC 60Hz 2.0kV / 1min.	
S-E	AC 60Hz 2.0kV / 1min.	
準拠規格 Standard	JIS C6436-1995/JIS C5310-1997	

訂正者 Designer		訂正事項 Content		訂正日 Date	
変更 Rev.					
改訂 Rev.					
訂正者 Designer		訂正事項 Content		訂正日 Date	
訂正者 Designer		訂正事項 Content		訂正日 Date	
訂正者 Designer		訂正事項 Content		訂正日 Date	
訂正者 Designer		訂正事項 Content		訂正日 Date	
訂正者 Designer		訂正事項 Content		訂正日 Date	
訂正者 Designer		訂正事項 Content		訂正日 Date	
訂正者 Designer		訂正事項 Content		訂正日 Date	

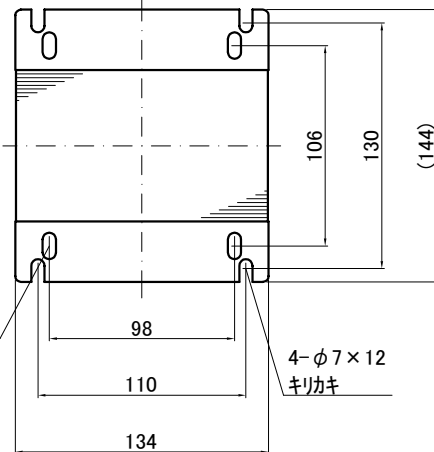
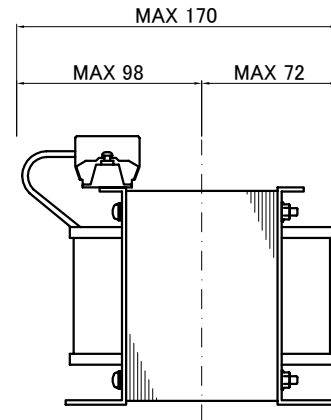
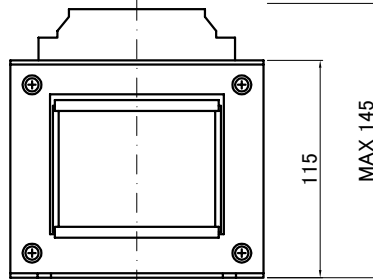
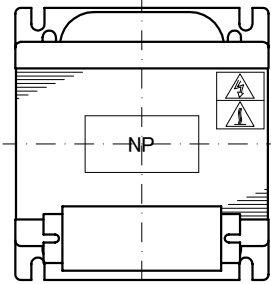

端子台 Terminals
CTKC-25S-6P M4 締付トルク 1.2~1.8N・m

端子台配列 Terminals Arrangement

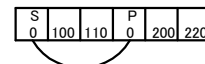

質量は標準仕様の値を記入しており、実測値と異なる場合もあります。

IMAI ELECTRIC
今井電機株式会社

設計 DESIGNED	DATE 18.07.10	品名 DESCRIPTION	单相乾式単巻変圧器 Dry type Auto Transformer	
DRAWN	M.Fujitaka	尺度 SCALE	単位 UNIT	型名 MODEL
APPROVED	N.Marukai	表面処理 FINISH	mm	ABS-1500-21
				図番 DRAWING NO.

摘要 REMARKS	
	S1A1500Q21 改訂 Ver.